

Glodalice s posteljom(posteljne glodalice) s CNC okruglim stolom

model: **RT 1000**

glodalice s posteljom s
kontinuiranim 0,001° okruglim stolom



WEMO-POWER RT 1000

Stol			
Dimenzije	mm	1.400 × 1.200	1.600 × 1.400
T-utori broj/širina/razmak	mm	9 / 22 / 125	
Mak. opterećenje stola	kg	8.000	
Kontinuirano okretanje stola	stupanj	0,001	
Procesni putovi			
X-osovina	mm	2.500	3.000
Y-osovina	mm	1.000	1.250
Z-osovina	mm	1.600 / 2.000	
Brzine			
Brzi hod	mm/min.	12.000 (X/Y) / 10.000 (Z)	
Pomak	mm/min.	5.000	
Vreteno			
Pričvršćivanje vretena	ISO	50	
Broj okretaja vretena	Ok./min.	4.000	
Motor vretena	kW	28 / 38	
Težina stroja	To.	25 – 30	32 – 36

model: **RT 1000**

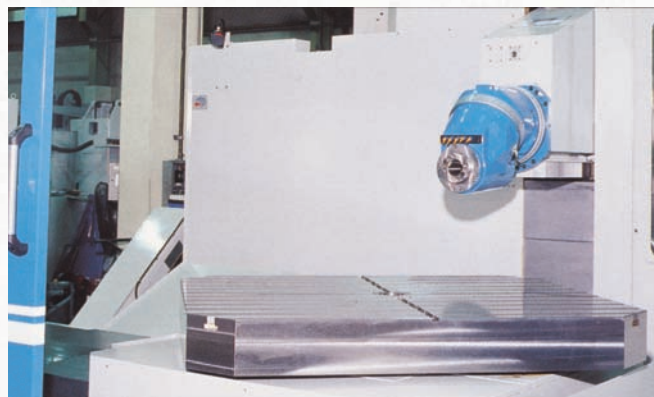

Veličina stola 1.400 × 1.200 mm

A2-glava (horizontalno / vertikalno) poprečni put 1.000 / 1.250 mm

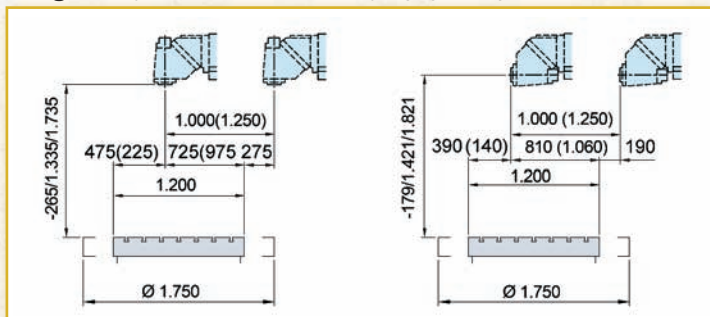

Veličina stola 1.600 × 1.400 mm

A2-glava (horizontalno / vertikalno) poprečni put 1.250 mm

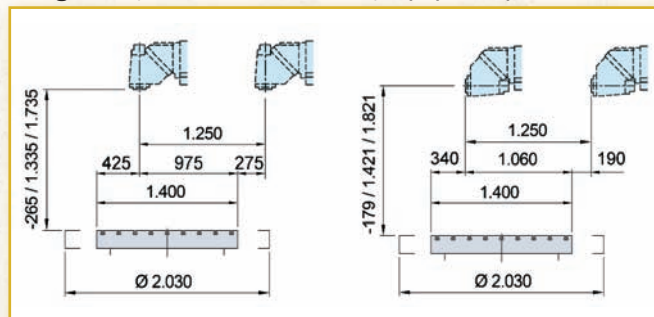

A4-glava (2,5° × 2,5°) poprečni put 1.000 / 1.250 mm

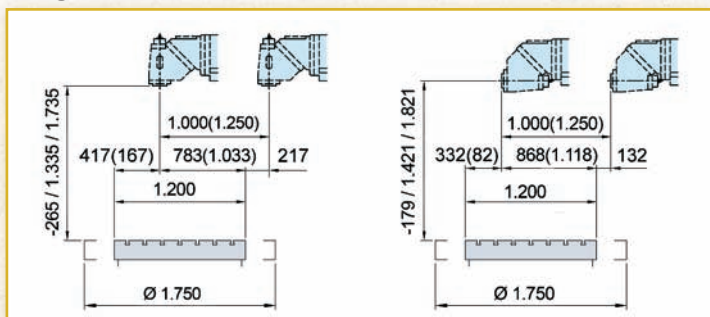

A4-glava (2,5° × 2,5°) poprečni put 1.250 mm

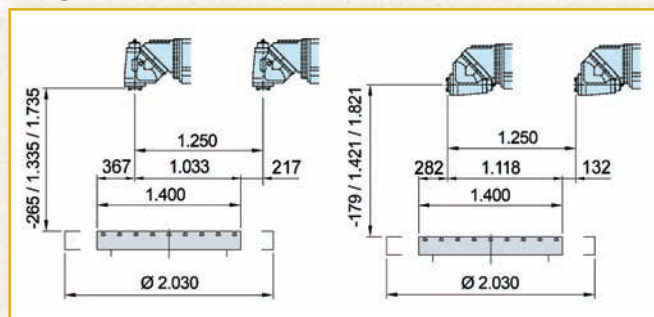

dimenzije stroja:

veličina stola:	1.400 × 1.200	1.600 × 1.400	mm
X:	2.500	3.000	mm
Y:	1.000	1.250	mm
Z:	1.600 / 2.000	1.600 / 2.000	mm

model: **RT 1000**

